

16X & 24X Floor Stand Assembly Instructions

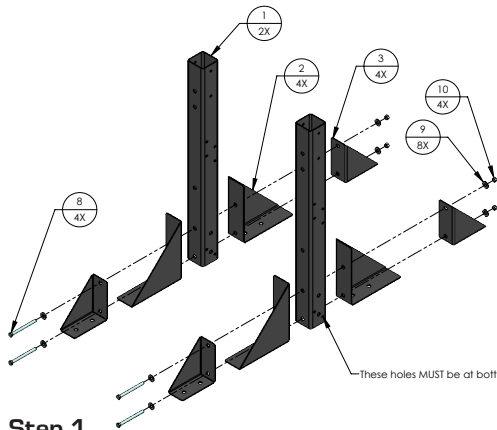

Step 1
On a flat surface, assemble the left and right stand columns and the feet as shown. Tighten the bolts to 30 ft-lbs +/- 3 ft-lbs.

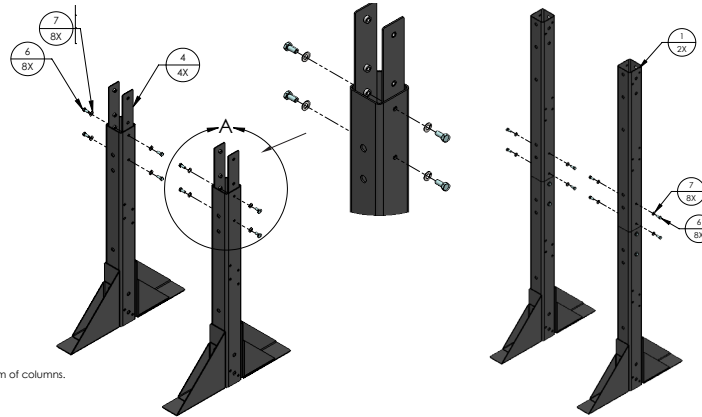

Step 2
Assemble the connector plates onto the left and right column & feet assemblies. Tighten the bolts to 17 ft-lbs +/- 2 ft-lbs.

Step 3
Assemble the upper columns onto the lower column and feet assemblies. Tighten the bolts to 17 ft-lbs +/- 2 ft-lbs.

Item #	Description	Qty
1	Column	4
2	Foot - 9"	4
3	Foot Brace	5
4	Connector Plate	4
5	Foot - 6"	1
6	Hex Cap Screw 5/16 - 18, 3/4"	16
7	Washer, 5/16"	16
8	Hex Cap Screw 3/8 - 18, 4.5"	14
9	Washer, 3/8"	28
10	Nut 3/8-16	14

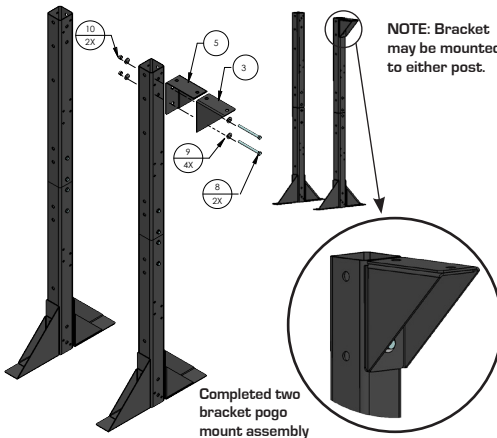

Step 4 (Optional pogo bracket assembly)
Assemble the pogo bracket onto the column assembly. Verify the top of the bracket is level with the top of the column before tightening. Tighten the bolts to 30 ft-lbs +/- 3 ft-lbs.



THE SHIPPING SPACER MUST REMAIN IN PLACE UNTIL THE CHARGER IS PERMANENTLY MOUNTED.

LIFTING THE CHARGER WITH THE SPACER REMOVED WILL RESULT IN DAMAGE TO THE CHARGER CHASSIS

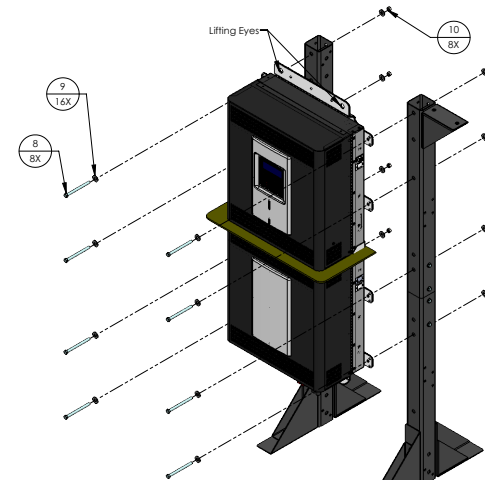

Step 5
Using appropriate equipment and safety precautions, pick up the charger via the lifting eyes. Fasten the charger to the left and right column & feet assemblies as shown. Tighten the bolts to 30 ft-lbs +/- 3 ft-lbs. Anchor the stand to the floor with appropriate hardware.



Once assembled, the entire charger stand assembly may be lifted and moved to the final mounting location.

WARNING TIP HAZARD! DO NOT ATTEMPT TO MOVE THE CHARGER MANUALLY OR WITHOUT PROPER EQUIPMENT!

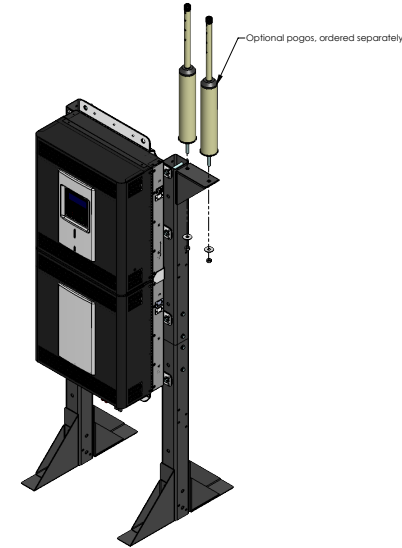

Step 6 (Optional pogo mount)
Attach the pogos (ordered separately) as shown. Note the inner pogo must be attached first as clearance to the adjacent hardware is minimal. Tighten the pogo nuts to 20 ft-lbs.