

5X Floor Stand Assembly Instructions

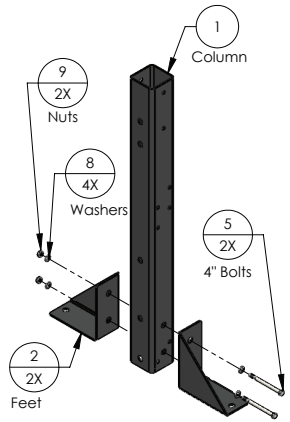

Step 1

Assemble left and right feet to column as shown. Note orientation of holes on column. Hand tighten only.

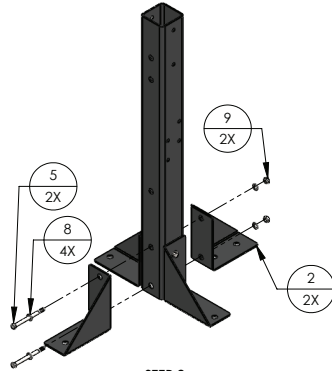

Step 2

Assemble front and back feet to column as shown. Hand tighten only.



Once this step is complete, it is recommended that the stand be placed in the intended mounting location and anchored to the floor. The column should be adjusted to vertical prior to tightening the fasteners to 10 ft-lbs.

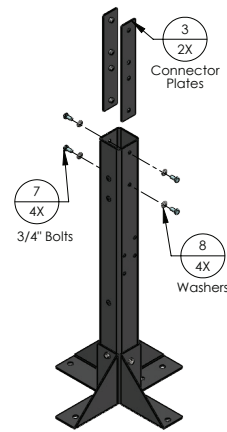

Step 3

Assemble connector plates to lower column as shown. Hand tighten only.

Item #	Description	Qty
1	Column	2
2	Foot	4
3	Connector Plate	2
4	Arm	4
5	Hex Cap Screw 5/16" - 18, 4"	8
6	Hex Cap Screw 5/16" - 18, 1.5"	4
7	Hex Cap Screw 5/16" - 18, 3/4"	8
8	Washer, 5/16"	32
9	Nut 5/16 - 18	16

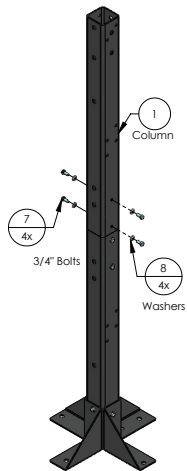

Step 4

Assemble connector plates to lower column. Hand tighten only. Verify upper column is vertical and flush with lower column. Tighten all fasteners to 10 ft-lbs.

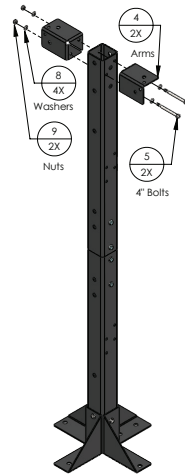

Step 5

Assemble arms to upper column as shown. Tighten all fasteners to 10 ft-lbs.

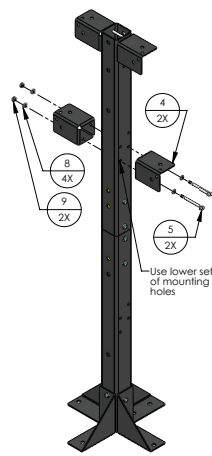

Step 6

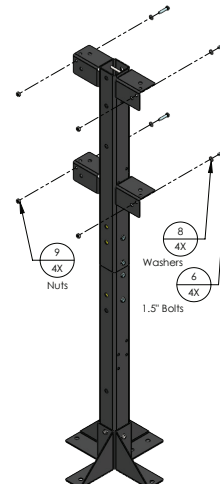

Step 7

Assemble fasteners to arms, to create studs for mounting the charger. Tighten all fasteners to 10 ft-lbs.



DO NOT MOUNT THE CHARGER UNLESS THE FEET HAVE BEEN PROPERLY ANCHORED.

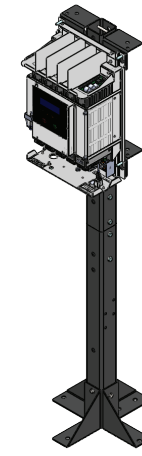

Step 8

Remove Charger cover and hang charger on studs. Fasten charger to arms as shown. Tighten all fasteners to 10 ft-lbs. Complete electrical installation (see manual) and replace charger cover.

